

Katalog

12/2006

HAUTAU ATRIUM S 50/S 120

für Kunststoff-Elemente



HAUTAU

HAUTAU-Katalog

Schiebe-Beschläge

HAUTAU

ATRIUM S 50 / S 120

12/2006

HAUTAU GmbH

Postfach 1151
D 31689 Helpsen
Telefon 05724/393-0
Telefax 05724/393-125
Info@HAUTAU.de
www.HAUTAU.de

Handelsregister Stadthagen · HRB-Nr. 2565

Bankverbindungen

Volksbank in Schaumburg eG (BLZ 25591413) Kto. 645273600
IBAN: DE19255914130645273600 · SWIFT: GENODEF1BCK

Postbank Hannover (BLZ 25010030) Kto. 3887-305
IBAN: DE63250100300003887305 · SWIFT: PBNKDEFF250

Umsatzsteuer-Identifikationsnummer: DE 811 213 544

Printed in Germany · Nachdruck, auch auszugsweise, nur mit schriftlicher Genehmigung des Herausgebers.

Im Sinne des Fortschritts behalten wir uns Konstruktionsänderungen und dadurch bedingte Abweichungen von den Abbildungen, Abmessungen, Gewichtsangaben usw. vor. Die Abbildungen zeigen die Artikel nicht in natürlicher Größe und stehen auch nicht im gleichen Verhältnis zueinander.



Inhaltsverzeichnis

	Seite
Aluplast 60	5
Aluplast 73	6
Deceuninck Monorail	7
Dimex Perfekt 60	8
Dimex Perfekt 70	9
Gealan	10
Heroal 070 S	11
Kömmerling SF2, Flügel 1386	12
Kömmerling SF2, Flügel 1391	13
Kömmerling SF3	14
LB Profile	15
Rehau S 717, Flügel 557.090	16
Rehau S 717, Flügel 557.140	17
Salamander	18
Schüco Corona S 74	19
Schüco Corona S 90	20
Thyssen	21
Veka Softline Ekosol, Flügel 105.240	22
Veka Softline Ekosol, Flügel 105.241	23
Veka Softline Schiebetür, Flügel 105.095	24
Veka Softline Schiebefenster, Flügel 105.102	25
Veka Softline Schiebefenster, Flügel 105.712	26
Veka Topline Zargenprofil 105.204	27
Wymar P 2400	28

Hinweis:

weitere Zeichnungen stehen im Internet unter www.HAUTAU.de zum downloaden zur Verfügung.



ATRIUM S 50 - Aluplast 60

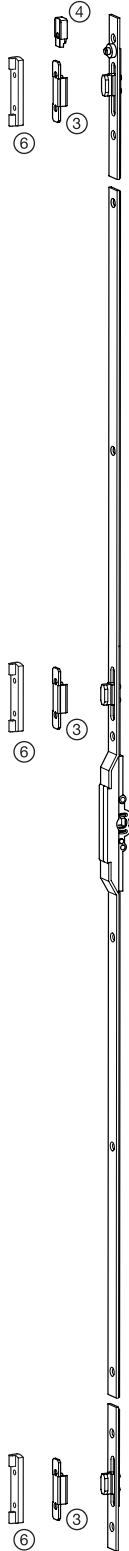

Artikelbezeichnung		Artikel-Code	Bedarf pro Flügel	Schließstellen
Karton Laufwerke S 50 ① ④		197117	1	-
Getriebe D 7,5 ②	Gr. FH			
	600 650 - 1049	202105		2
	1000 1050 - 1849	202108	1	2
	1800 1850 - 2350	202111		3
Schließplatten ③		195930	n. FH	-
Flügelanschlag (optional) ⑤	weiß	187480		-
	schwarz	187477	2	-
Beutel Unterlegteile Schließplatten ⑥		197417	n. FH	-

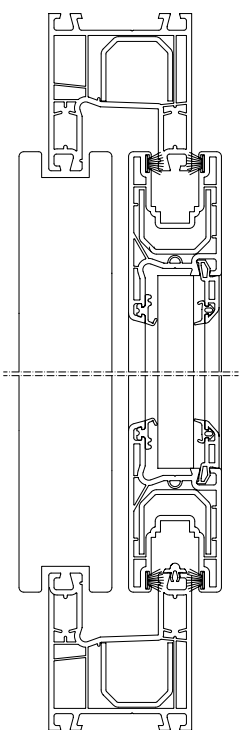
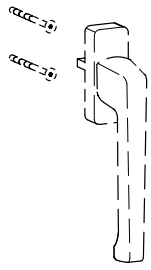



ATRIUM S 50 / S 120 - Aluplast 73

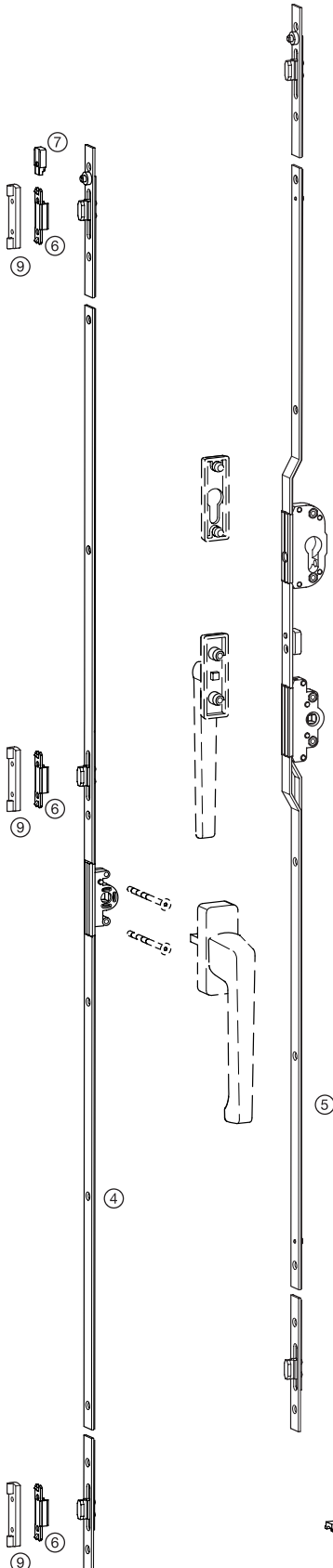

Artikelbezeichnung

Artikelbezeichnung	Artikel-Code	Bedarf pro Flügel	Schließstellen
Karton Laufwerke S 50 ① ⑦	197123	1	-
Karton Laufwerke S 120 ② ⑦	196202	1	-
Beutel Unterlegteile S 120 Laufwerke ③	197393	1	-
Getriebe D 15 ④	Gr.	FH	
	600	650 - 1049	2
	1000	1050 - 1849	2
	1800	1850 - 2350	3
Getriebe D 15, abschließbar ⑤	1800	1850 - 2350	2
Schließplatten ⑥	195930	n. FH	-
Flügelanschlag (optional) ⑧	weiß	187480	-
	schwarz	187477	2
Beutel Unterlegteile Schließplatten ⑨	197417	n. FH	-

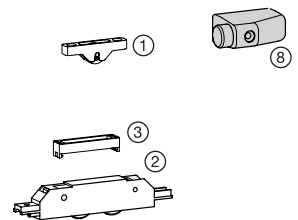
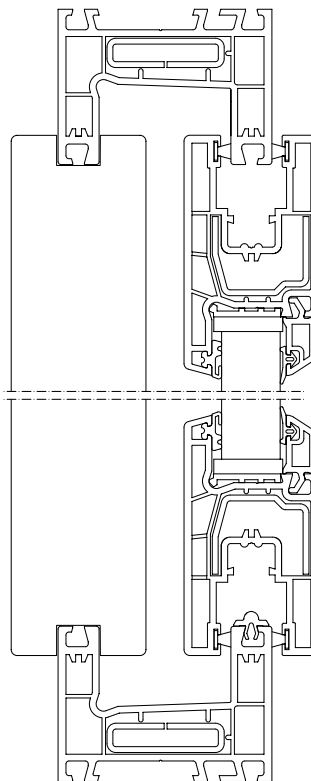



ATRIUM S 50 / S 120 - Deceuninck Monorail

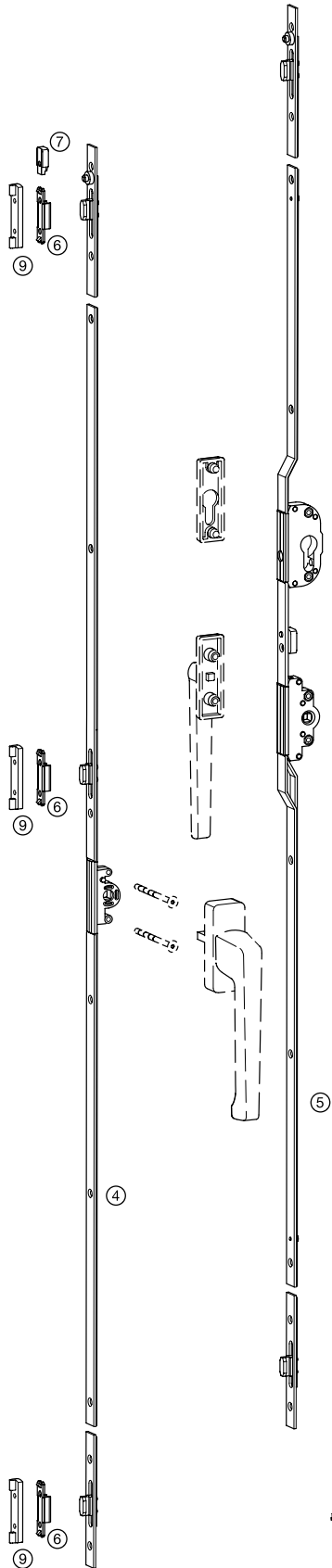

Artikelbezeichnung

Artikelbezeichnung	Artikel-Code	Bedarf pro Flügel	Schließstellen	
Karton Laufwerke S 50 ① ⑦	197120	1	-	
Karton Laufwerke S 120 ② ⑦	196202	1	-	
Beutel Unterlegteile S 120 Laufwerke ③	197411	1	-	
Getriebe D 15 ④	Gr.	FH		
	600	650 - 1049	202132	2
	1000	1050 - 1849	202135	1
	1800	1850 - 2350	202138	3
Getriebe D 15, abschließbar ⑤	1800	1850 - 2350	202213	1
Schließplatten ⑥		n. FH	195930	-
Flügelanschlag (optional) ⑧		weiß	187480	-
		schwarz	187477	2
Beutel Unterlegteile Schließplatten ⑨		n. FH	197420	-

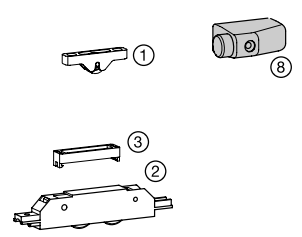
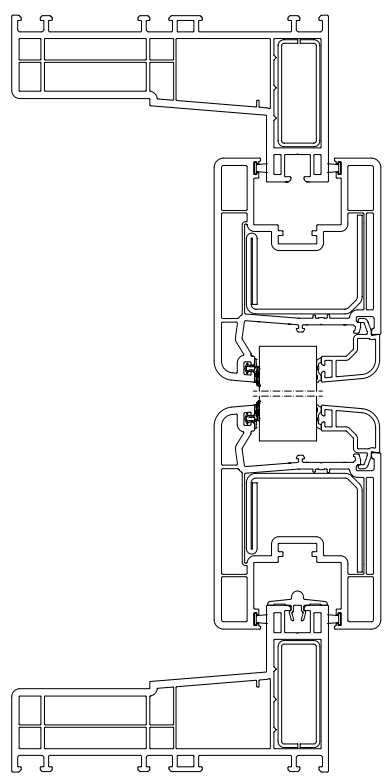
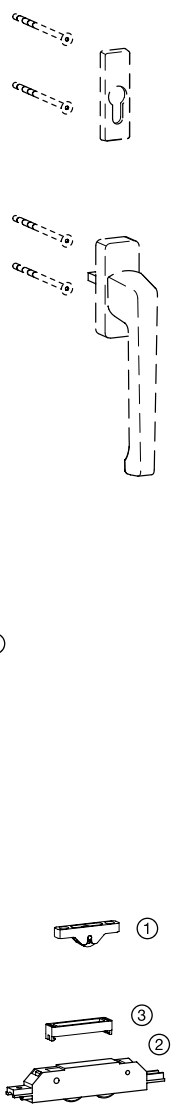



ATRIUM S 50 / S 120 - Dimex Perfekt 60

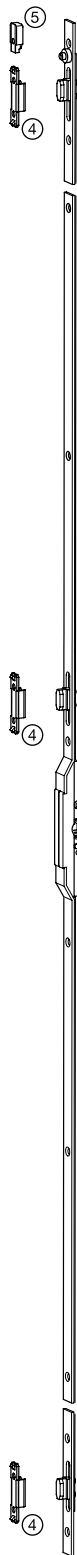

Artikelbezeichnung	Artikel-Code	Bedarf pro Flügel	Schließstellen
Karton Laufwerke S 50 ① ⑤	197120	1	-
Karton Laufwerke S 120 ② ⑤	196202	1	-
Getriebe D 7,5 ③	Gr. FH		
	600 650 - 1049		2
	1000 1050 - 1849	1	2
	1800 1850 - 2350		3
Schließplatten ④		n. FH	-
Flügelanschlag (optional) ⑥	weiß		-
	schwarz	2	-

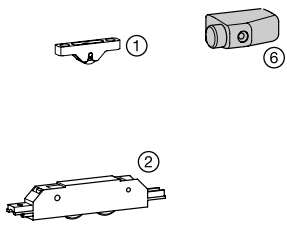
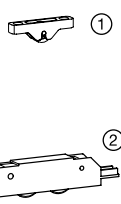
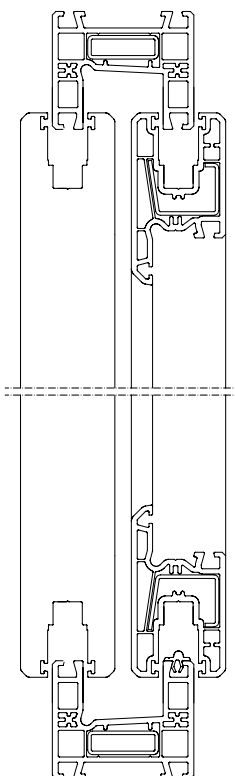
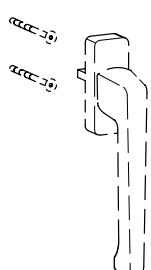



ATRIUM S 50 / S 120 - Dimex Perfekt 70

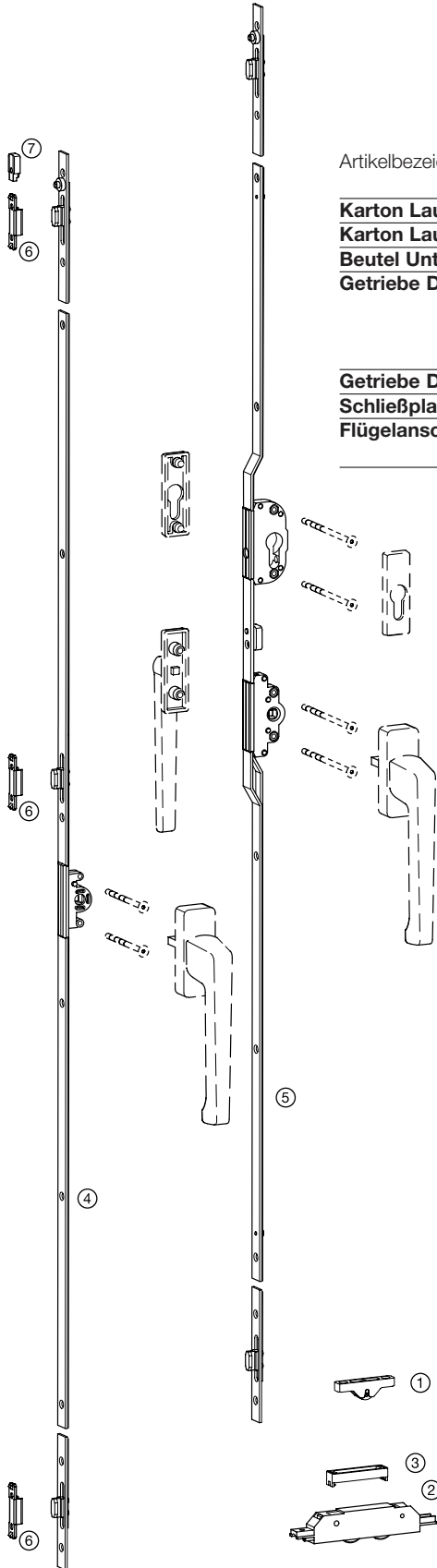

Artikelbezeichnung

Artikelbezeichnung	Artikel-Code	Bedarf pro Flügel	Schließstellen		
Karton Laufwerke S 50 ① ⑦	197120	1	-		
Karton Laufwerke S 120 ② ⑦	196202	1	-		
Beutel Unterlegteile S 120 Laufwerke ③	197396	1	-		
Getriebe D 15 ④	Gr.		FH		
	600	650 - 1049	202132	2	
	1000	1050 - 1849	202135	1	2
	1800	1850 - 2350	202138		3
Getriebe D 15, abschließbar ⑤	1800	1850 - 2350	202213	n. FH	-
Schließplatten ⑥			202890	n. FH	-
Flügelanschlag (optional) ⑧		weiß	187480		-
		schwarz	187477	2	-

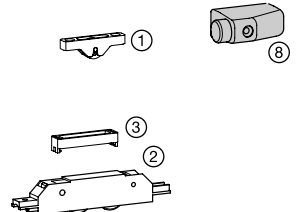
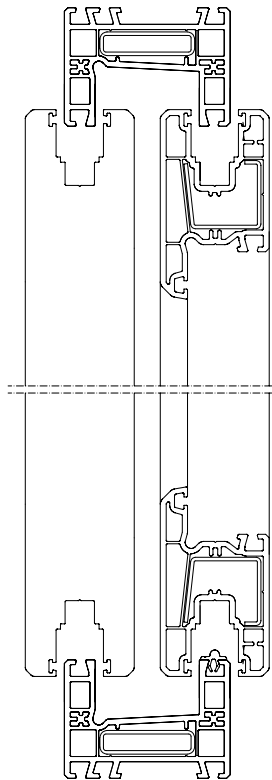



ATRIUM S 50 / S 120 - Gealan

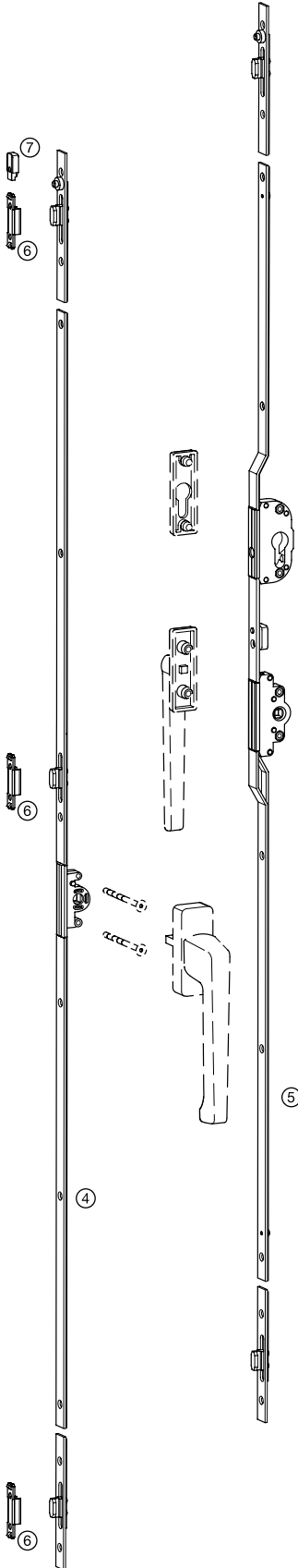

Artikelbezeichnung

Artikelbezeichnung	Artikel-Code	Bedarf pro Flügel	Schließstellen	
Karton Laufwerke S 50 ① ⑦	197120	1	-	
Karton Laufwerke S 120 ② ⑦	196202	1	-	
Beutel Unterlegteile S 120 Laufwerke ③	197396	1	-	
Getriebe D 15 ④	Gr.	FH		
	600	650 - 1049	202132	2
	1000	1050 - 1849	202135	1
	1800	1850 - 2350	202138	3
Getriebe D 15, abschließbar ⑤	1800	1850 - 2350	202213	n. FH
Schließplatten ⑥			202890	n. FH
Flügelanschlag (optional) ⑧		weiß	187480	-
		schwarz	187477	2

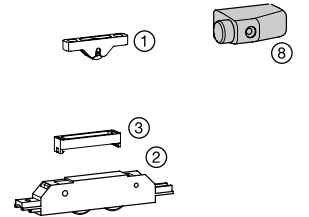
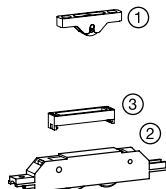
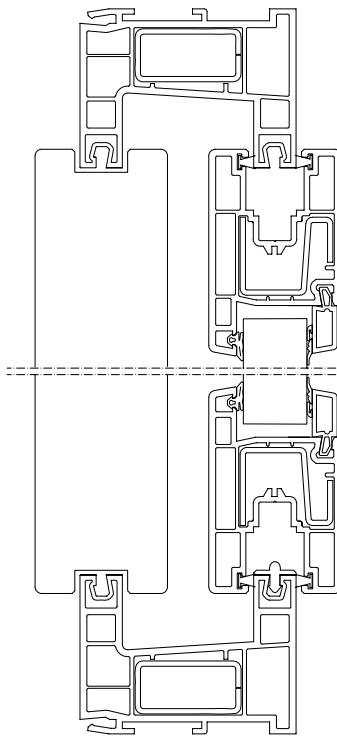



ATRIUM S 50 / S 120 - Heroal 070 S

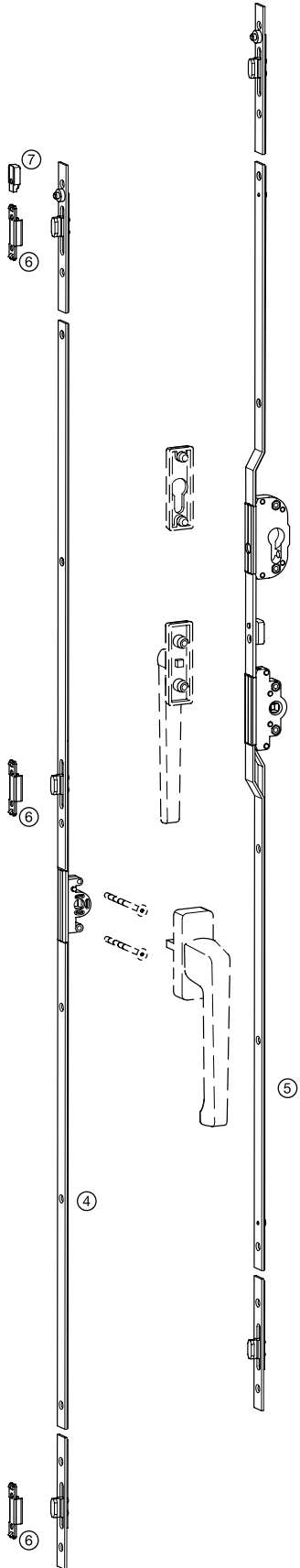

Artikelbezeichnung	Artikel-Code	Bedarf pro Flügel	Schließstellen
Karton Laufwerke S 50 ① ⑦	197123	1	-
Karton Laufwerke S 120 ② ⑦	196202	1	-
Getriebe D 15 ④			
Gr. 600	FH 650 - 1049		2
1000	1050 - 1849	1	2
1800	1850 - 2350		3
Getriebe D 15, abschließbar ⑤	202213	1	2
Schließplatten ⑥	195930	n. FH	-
Flügelanschlag (optional) ⑧	weiß	187480	-
	schwarz	187477	-

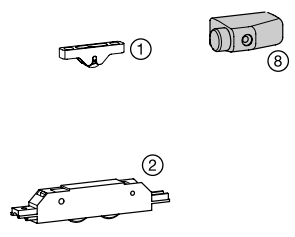
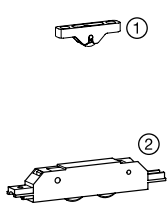
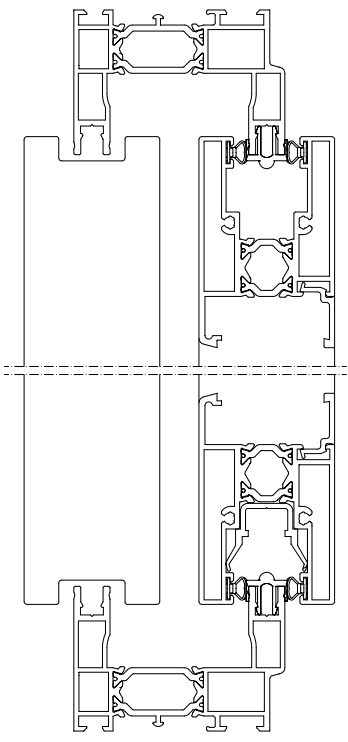
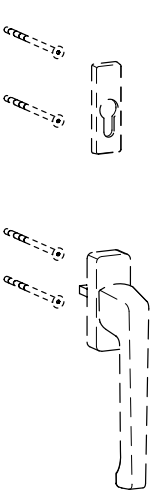



ATRIUM S 50 / S 120 - Kömmerling SF2, Flügel 1386

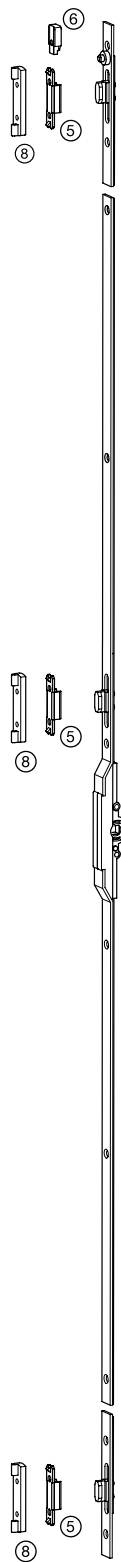

Artikelbezeichnung	Artikel-Code	Bedarf pro Flügel	Schließstellen		
Karton Laufwerke S 50 ① ⑥	197123	1	-		
Karton Laufwerke S 120 ② ⑥	196202	1	-		
Beutel Distanzstücke S 120 Laufwerk ③	204193	1	-		
Getriebe D 7,5 ④	Gr.	FH			
	600	650 - 1049	202105	2	
	1000	1050 - 1849	202108	1	2
	1800	1850 - 2350	202111		3
Schließplatten ⑤		195930	n. FH	-	
Flügelanschlag (optional) ⑦		weiß	187480	-	
		schwarz	187477	2	-
Beutel Unterlegteile Schließplatten ⑧		153565	n. FH	-	

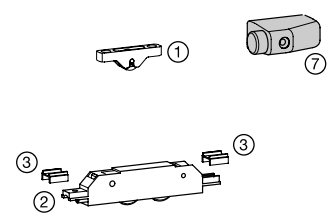
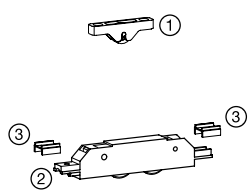
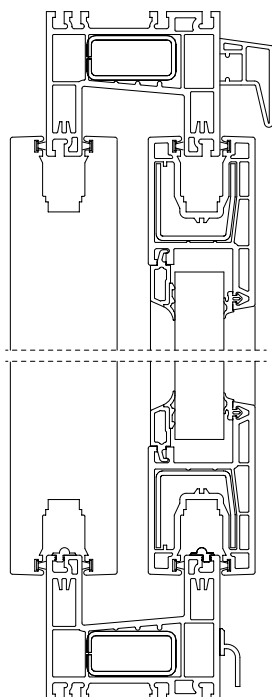
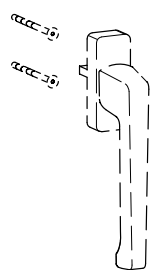



ATRIUM S 50 / S 120 - Kömmerling SF2, Flügel 1391

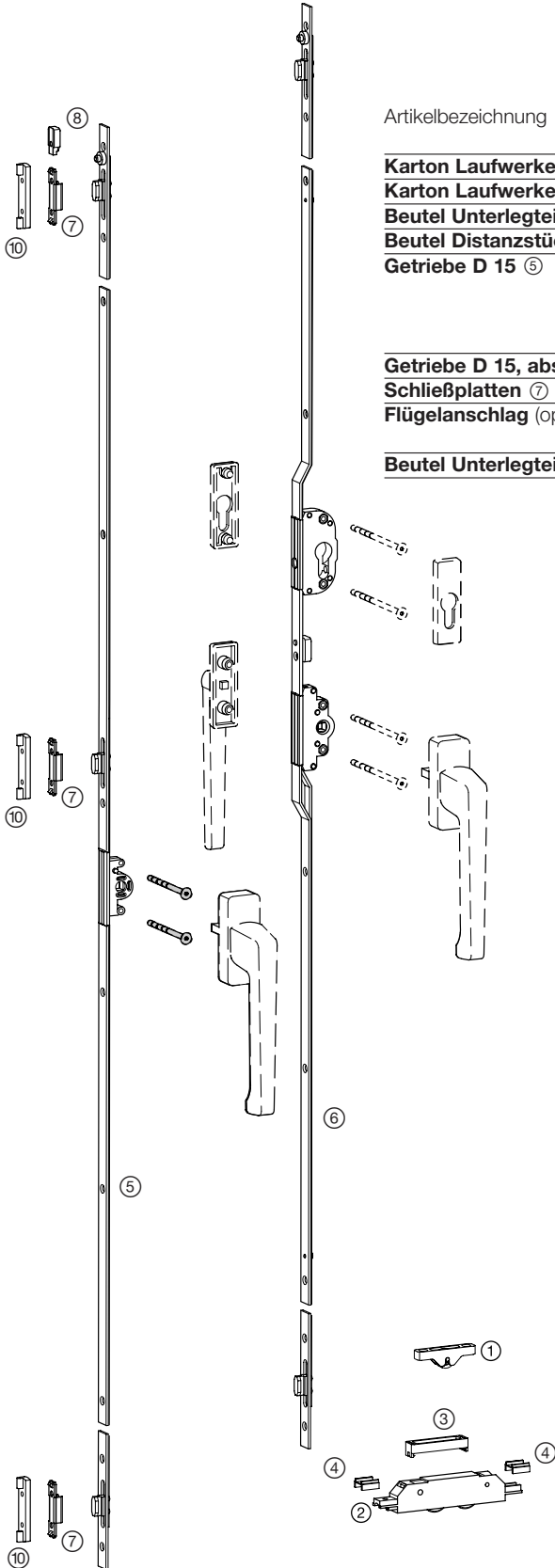

Artikelbezeichnung

Artikelbezeichnung	Artikel-Code	Bedarf pro Flügel	Schließstellen	
Karton Laufwerke S 50 ① ⑧	197123	1	-	
Karton Laufwerke S 120 ② ⑧	196202	1	-	
Beutel Unterlegteile S 120 Laufwerke ③	202920	1	-	
Beutel Distanzstücke S 120 Laufwerk ④	204193	1	-	
Getriebe D 15 ⑤	Gr.			
	600	FH 650 - 1049	2	
	1000	1050 - 1849	1	
	1800	1850 - 2350	202138	3
Getriebe D 15, abschließbar ⑥	202213	1	2	
Schließplatten ⑦	195930	n. FH	-	
Flügelanschlag (optional) ⑨	weiß		-	
	schwarz		2	
Beutel Unterlegteile Schließplatten ⑩	153565	n. FH	-	

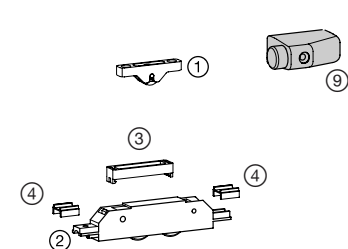
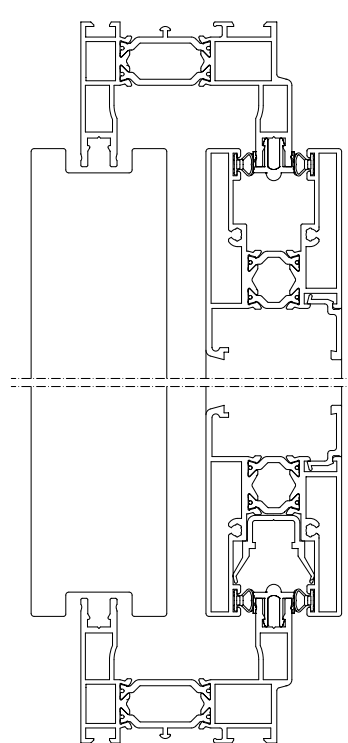



ATRIUM S 50 - KÖmmerling SF3

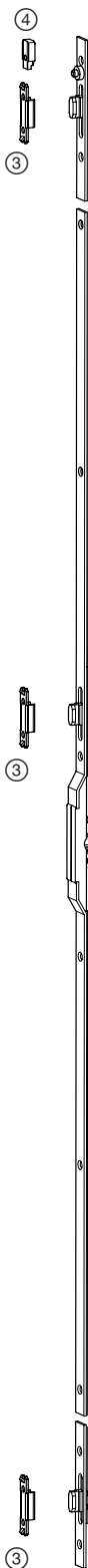

Artikelbezeichnung		Artikel-Code	Bedarf pro Flügel	Schließstellen
Karton Laufwerke S 50 ① ④		197117	1	-
Getriebe D 7,5 ②	Gr. FH			
	600 650 - 1049	202105		2
	1000 1050 - 1849	202108	1	2
	1800 1850 - 2350	202111		3
Schließplatten ③		196196	n. FH	-
Flügelanschlag (optional) ⑤	weiß	187480		-
	schwarz	187477	2	-

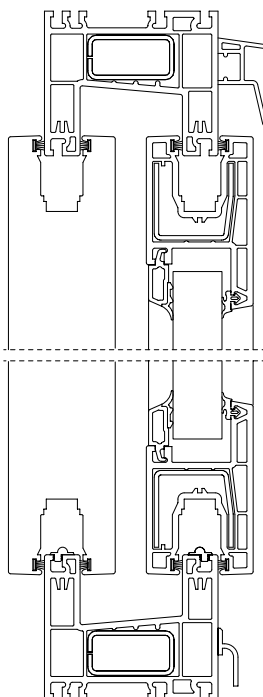
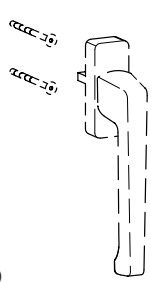



ATRIUM S 50 / S 120 - LB Profile

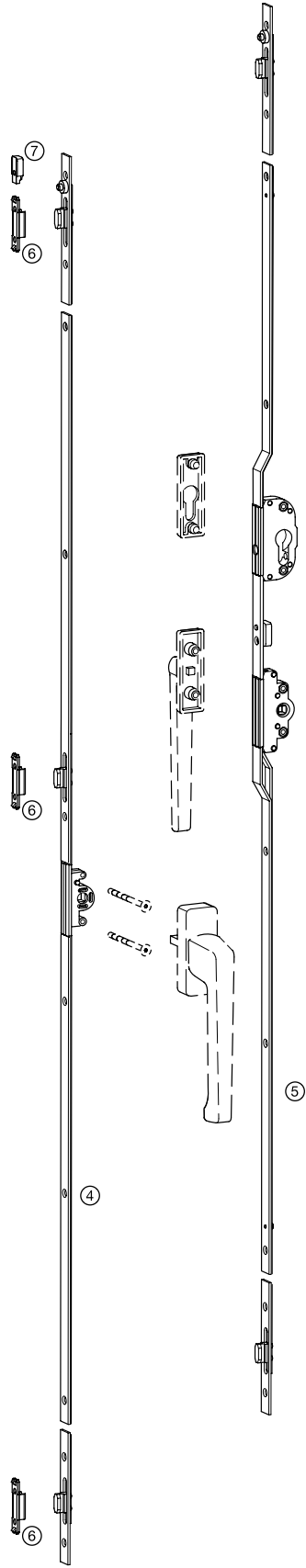

Artikelbezeichnung	Artikel-Code	Bedarf pro Flügel	Schließstellen	
Karton Laufwerke S 50 ① ⑦	197123	1	-	
Karton Laufwerke S 120 ② ⑦	196202	1	-	
Beutel Unterlegteile S 120 Laufwerke ③	197399	1	-	
Getriebe D 15 ④	Gr.	FH		
	600	650 - 1049	202132	2
	1000	1050 - 1849	202135	1
	1800	1850 - 2350	202138	3
Getriebe D 15, abschließbar ⑤	1800	1850 - 2350	202213	1
Schließplatten ⑥		n. FH	196068	-
Flügelanschlag (optional) ⑧		weiß	187480	-
		schwarz	187477	2

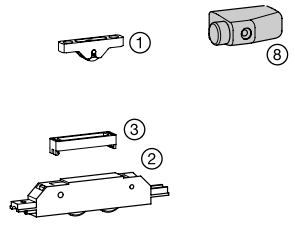
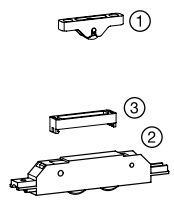
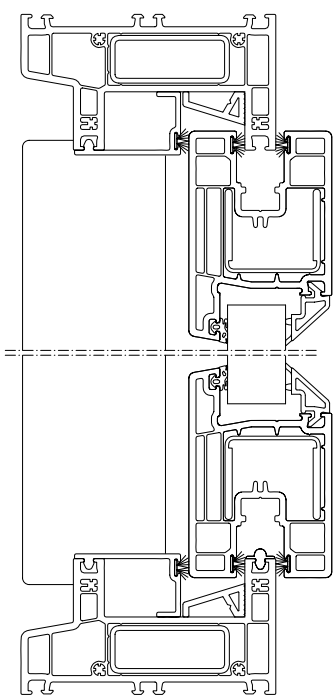

ATRIUM S 50 / S 120 - Rehau S 717, Flügel 557.090

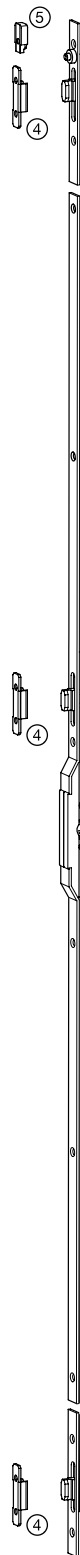

Artikelbezeichnung	Artikel-Code	Bedarf pro Flügel	Schließstellen
Karton Laufwerke S 50 ① ⑤	197126	1	-
Karton Laufwerke S 120 ② ⑤	196202	1	-
Getriebe D 7,5 ③	Gr. FH		
	600 650 - 1049		2
	1000 1050 - 1849	1	2
	1800 1850 - 2350		3
Schließplatten ④		n. FH	-
Flügelanschlag (optional) ⑥			-
	weiß		-
	schwarz	2	-
Laufschiene 4 mm ⑦	3500 mm, EV1	1	-

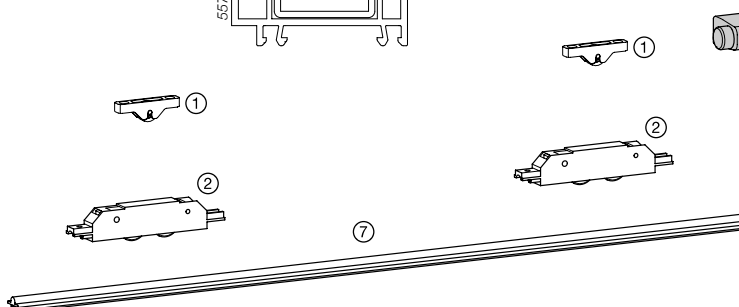
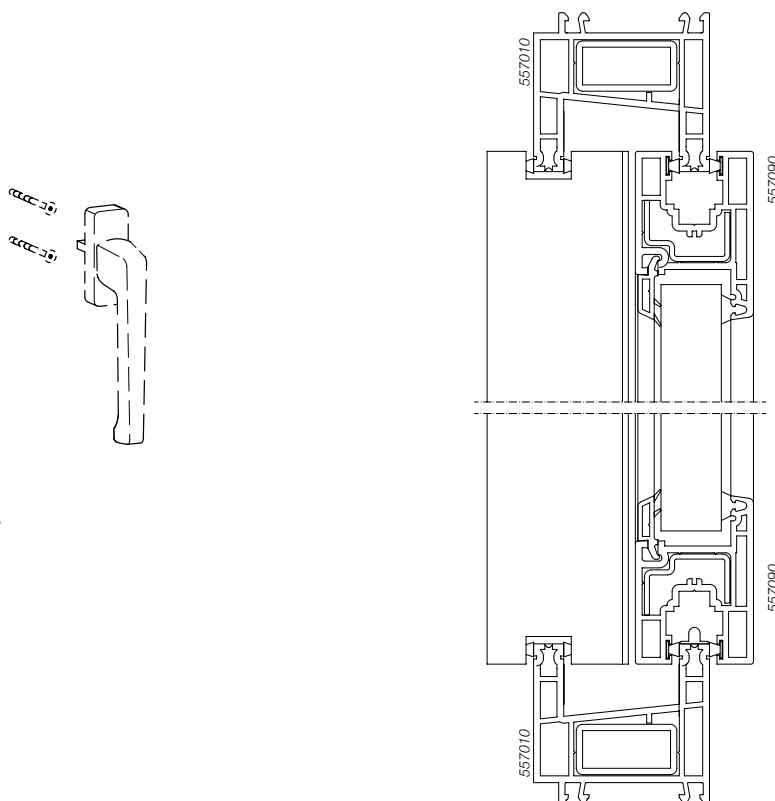



ATRIUM S 50 / S 120 - Rehau S 717, Flügel 557.140

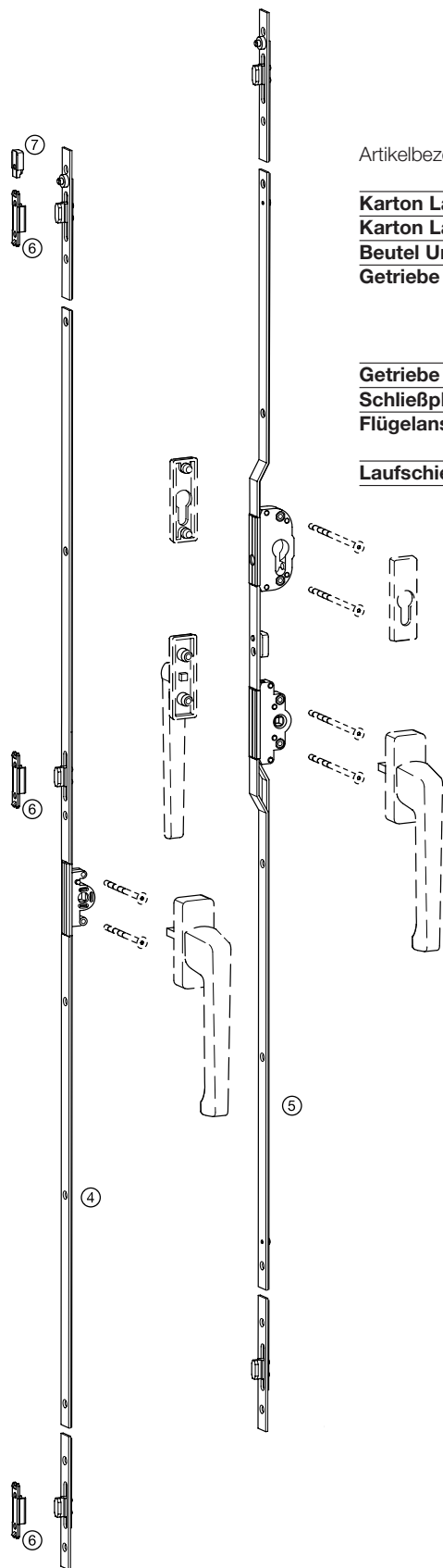

Artikelbezeichnung

Artikelbezeichnung	Artikel-Code	Bedarf pro Flügel	Schließstellen		
Karton Laufwerke S 50 ① ⑦	197123	1	-		
Karton Laufwerke S 120 ② ⑦	196202	1	-		
Beutel Unterlegteile S 120 Laufwerke ③	197414	1	-		
Getriebe D 15 ④	Gr.		FH		
	600	650 - 1049	202132	2	
	1000	1050 - 1849	202135	1	2
	1800	1850 - 2350	202138	3	
Getriebe D 15, abschließbar ⑤	1800	1850 - 2350	202213	1	2
Schließplatten ⑥		n. FH	196065	-	
Flügelanschlag (optional) ⑧		weiß	187480	-	
		schwarz	187477	2	
Laufschiene 4 mm ⑨		3500 mm, EV1	202929	1	-

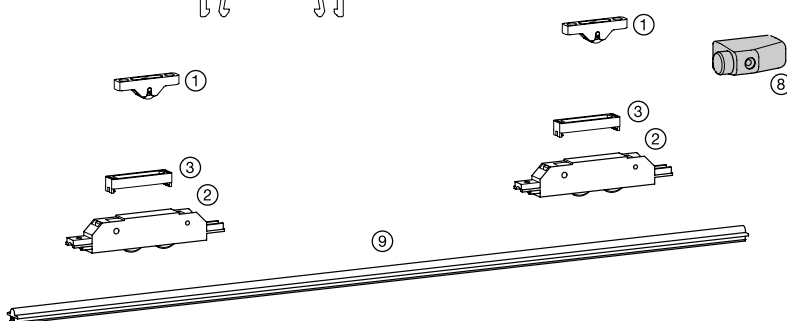
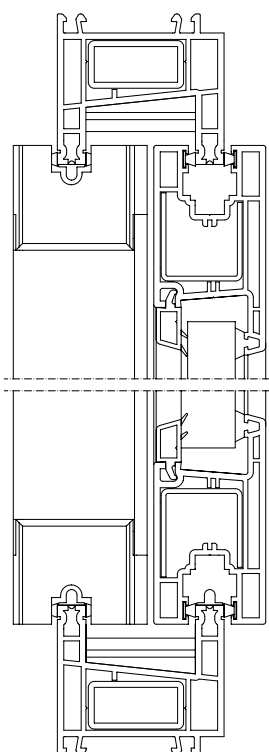



ATRIUM S 50 / S 120 - Salamander

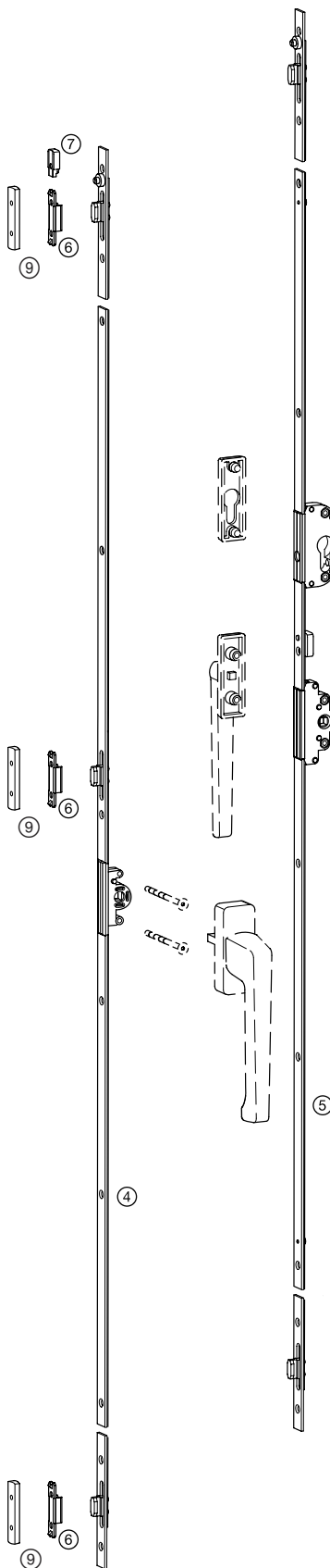

Artikelbezeichnung

Karton Laufwerke S 50 ① ⑦

Karton Laufwerke S 120 ② ⑦

Getriebe D 15 ④

Gr.	FH
600	650 - 1049
1000	1050 - 1849
1800	1850 - 2350

Getriebe D 25, abschließbar ⑤

Schließplatten ⑥

Flügelanschlag (optional) ⑧

weiß
schwarz

Beutel Unterlegteile Schließplatten ⑨

Artikel-Code

Bedarf
pro Flügel

Schließ-
stellen

197129	1	-
196202	1	-
202132		2
202135	1	2
202138		3
202159	1	2
195930	n. FH	-
187480		-
187477	2	-
197435	n. FH	-

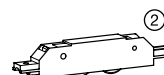
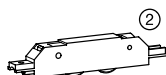
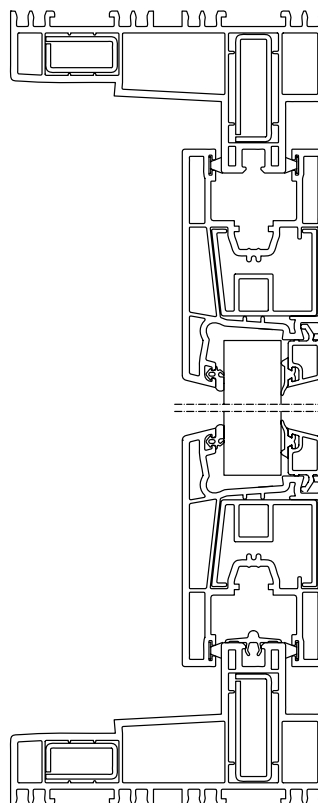



ATRIUM S 50 / S 120 - Schüco Corona S 74

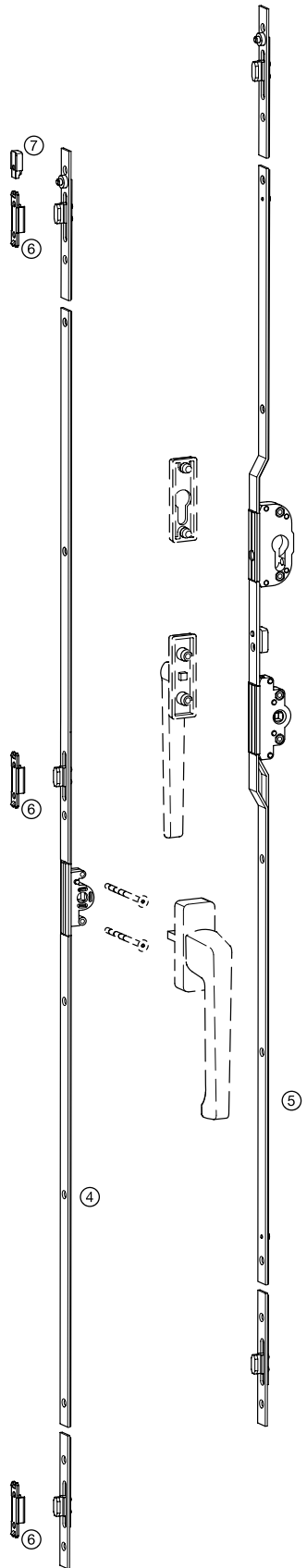

Artikelbezeichnung	Artikel-Code	Bedarf pro Flügel	Schließstellen		
Karton Laufwerke S 50 ① ⑦	197120	1	-		
Karton Laufwerke S 120 ② ⑦	196202	1	-		
Beutel Unterlegteile S 120 Laufwerke ③	197396	1	-		
Getriebe D 15 ④	Gr.	FH			
	600	650 - 1049	202132	2	
	1000	1050 - 1849	202135	1	2
	1800	1850 - 2350	202138	3	
Getriebe D 15, abschließbar ⑤	1800	1850 - 2350	202213	1	2
Schließplatten ⑥			196068	n. FH	-
Flügelanschlag (optional) ⑧		weiß	187480		-
		schwarz	187477	2	-

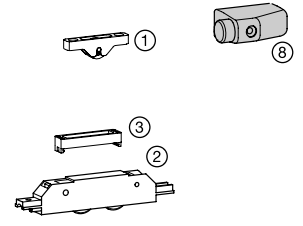
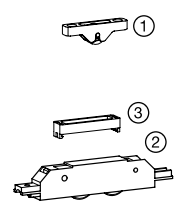
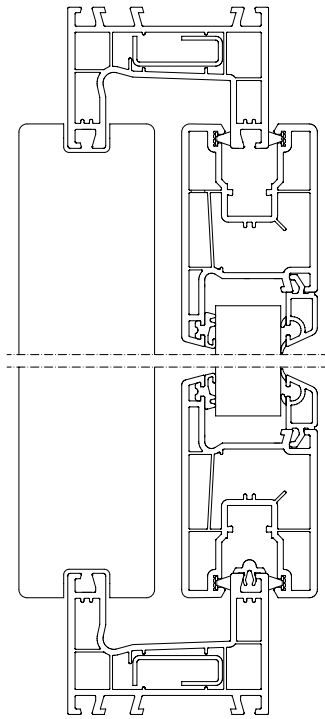
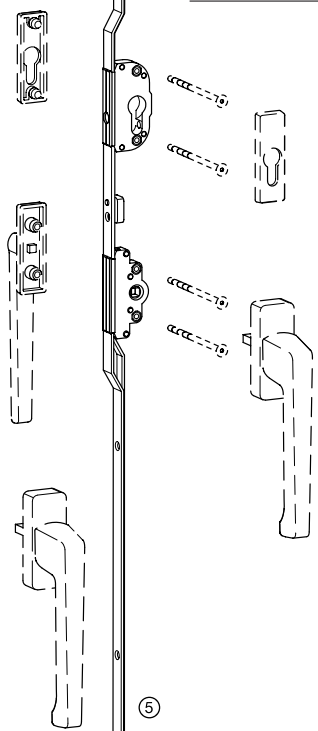



ATRIUM S 50 / S 120 - Schüco Corona S 90

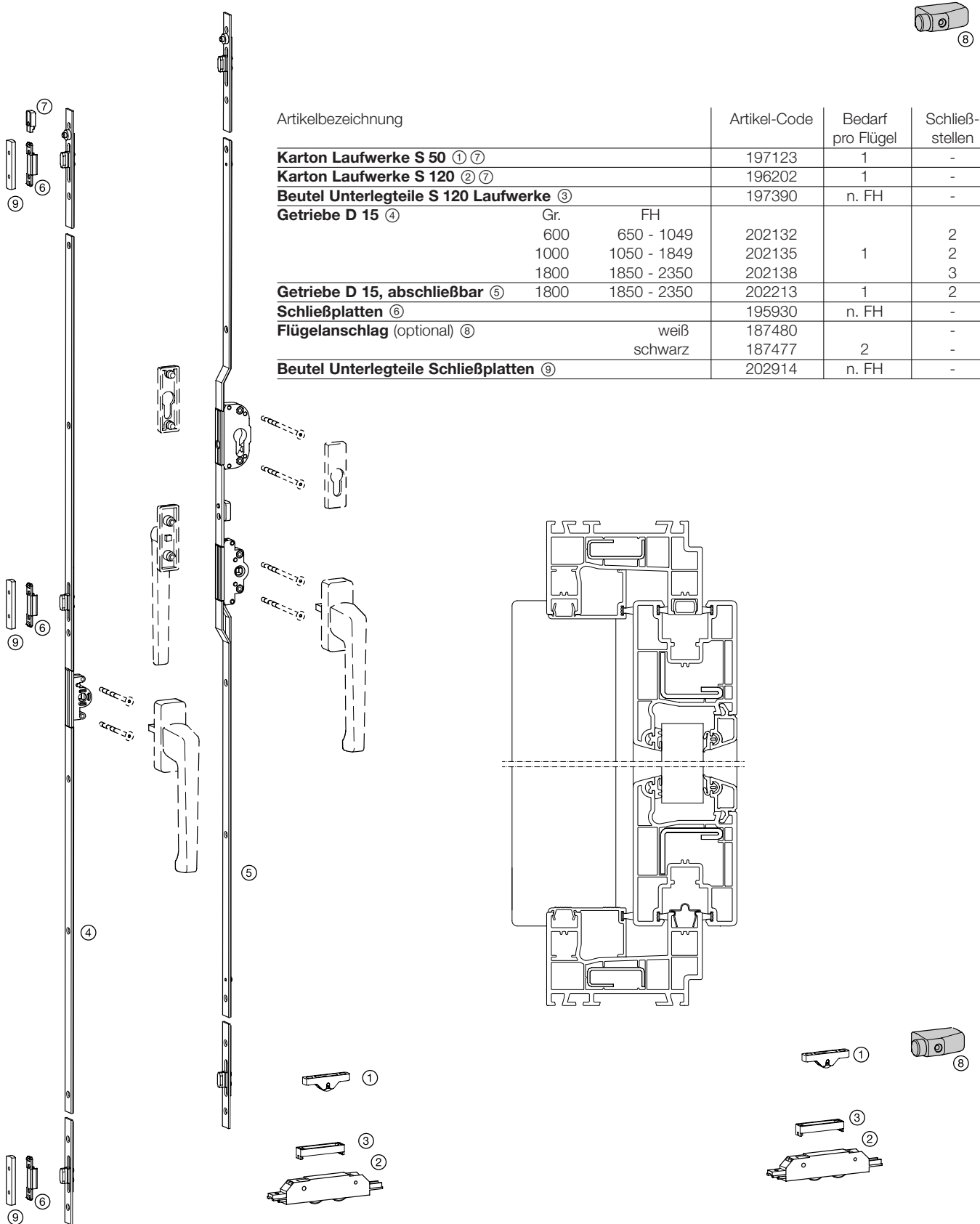

Artikelbezeichnung

Artikelbezeichnung	Artikel-Code	Bedarf pro Flügel	Schließstellen		
Karton Laufwerke S 50 ① ⑦	197123	1	-		
Karton Laufwerke S 120 ② ⑦	196202	1	-		
Beutel Unterlegteile S 120 Laufwerke ③	197390	n. FH	-		
Getriebe D 15 ④	Gr.	FH			
	600	650 - 1049	202132	2	
	1000	1050 - 1849	202135	1	2
	1800	1850 - 2350	202138	1	3
Getriebe D 15, abschließbar ⑤	1800	1850 - 2350	202213	1	2
Schließplatten ⑥			195930	n. FH	-
Flügelanschlag (optional) ⑧		weiß	187480		-
		schwarz	187477	2	-
Beutel Unterlegteile Schließplatten ⑨			202914	n. FH	-



ATRIUM S 50 / S 120 - Thyssen

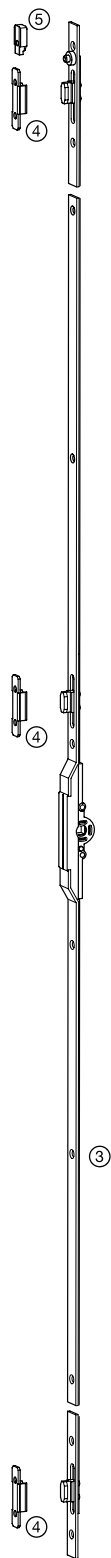

Artikelbezeichnung	Artikel-Code	Bedarf pro Flügel	Schließstellen
Karton Laufwerke S 50 ① ⑤	197120	1	-
Karton Laufwerke S 120 ② ⑤	196202	1	-
Getriebe D 7,5 ③	Gr. FH		
	600 650 - 1049		2
	1000 1050 - 1849	1	2
	1800 1850 - 2350		3
Schließplatten ④		n. FH	-
Flügelanschlag (optional) ⑥	weiß		-
	schwarz	2	-

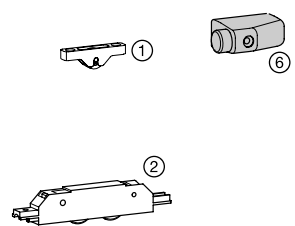
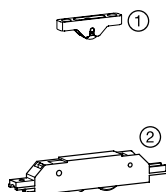
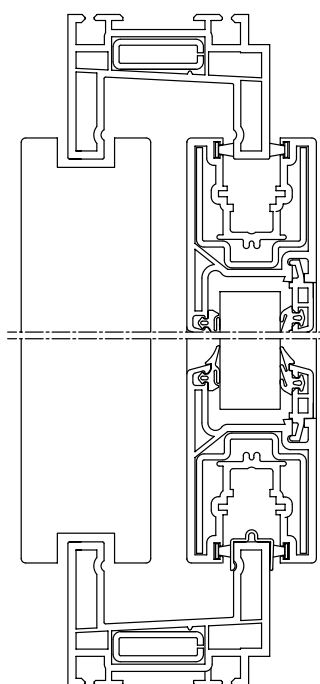
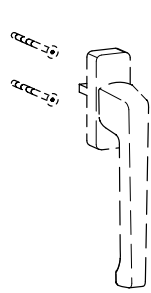



ATRIUM S 50 / S 120 - Veka Softline Ekosol, Flügel 105.240

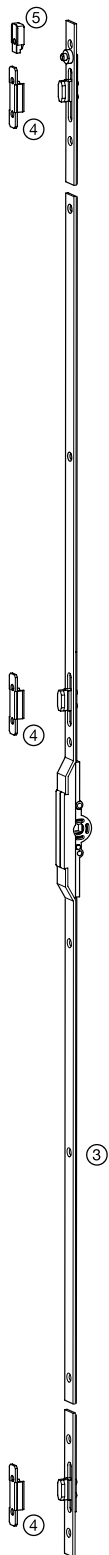

Artikelbezeichnung	Artikel-Code	Bedarf pro Flügel	Schließstellen
Karton Laufwerke S 50 ① ⑤	197123	1	-
Karton Laufwerke S 120 ② ⑤	196202	1	-
Getriebe D 7,5 ③	Gr. FH		
	600 650 - 1049		2
	1000 1050 - 1849	1	2
	1800 1850 - 2350		3
Schließplatten ④		n. FH	-
Flügelanschlag (optional) ⑥	weiß		-
	schwarz	2	-

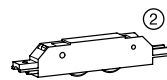
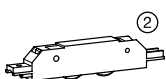
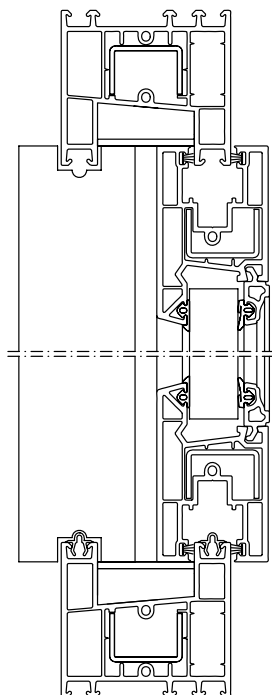
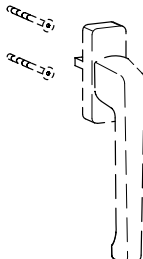



ATRIUM S 50 / S 120 - Veka Softline Ekosol, Flügel 105.241

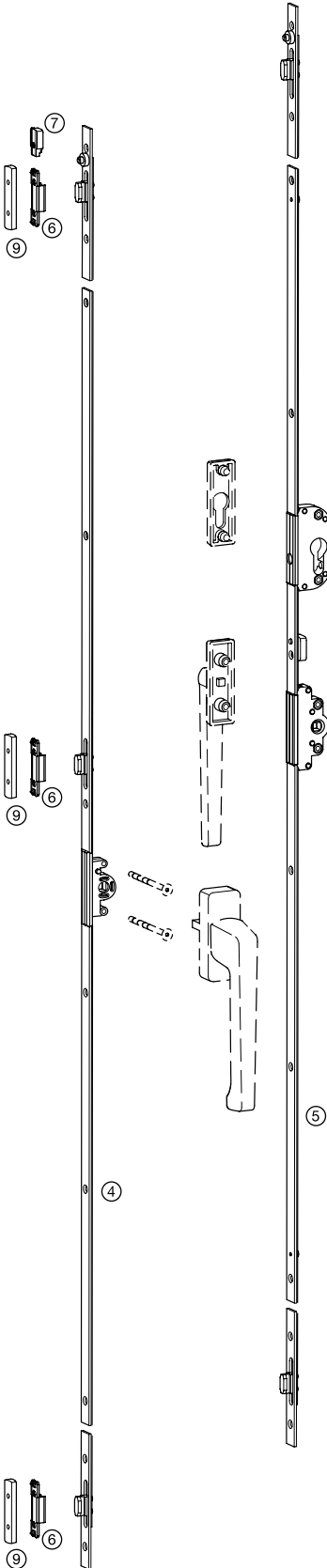

Artikelbezeichnung

Artikelbezeichnung	Artikel-Code	Bedarf pro Flügel	Schließstellen
Karton Laufwerke S 50 ① ⑦	197123	1	-
Karton Laufwerke S 120 ② ⑦	196202	1	-
Beutel Unterlegteile S 120 Laufwerke ③	197408	1	-
Getriebe D 15 ④	Gr.		
	600	FH 650 - 1049	2
	1000	1050 - 1849	2
	1800	1850 - 2350	3
Getriebe D 25, abschließbar ⑤	1800	1850 - 2350	2
Schließplatten ⑥	196196	n. FH	-
Flügelanschlag (optional) ⑧	weiß	187480	-
	schwarz	187477	-
Beutel Unterlegteile Schließplatten ⑨	202911	n. FH	-

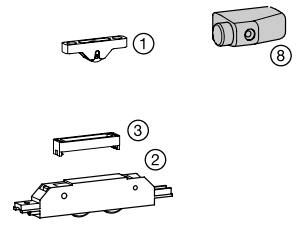
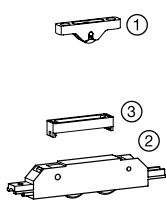
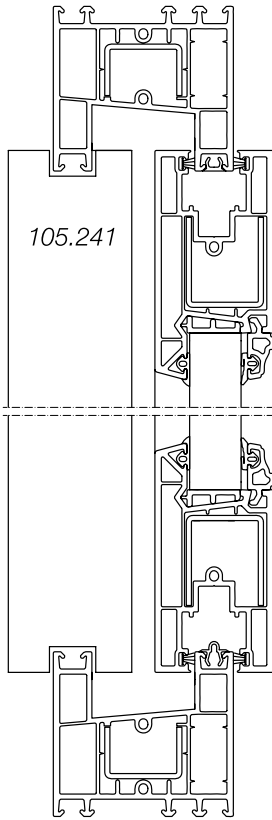
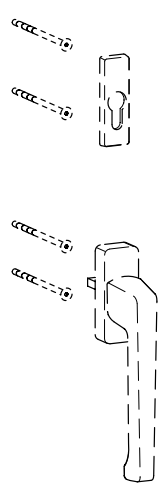



ATRIUM S 50 / S 120 - Veka Softline Schiebetür, Flügel 105.095

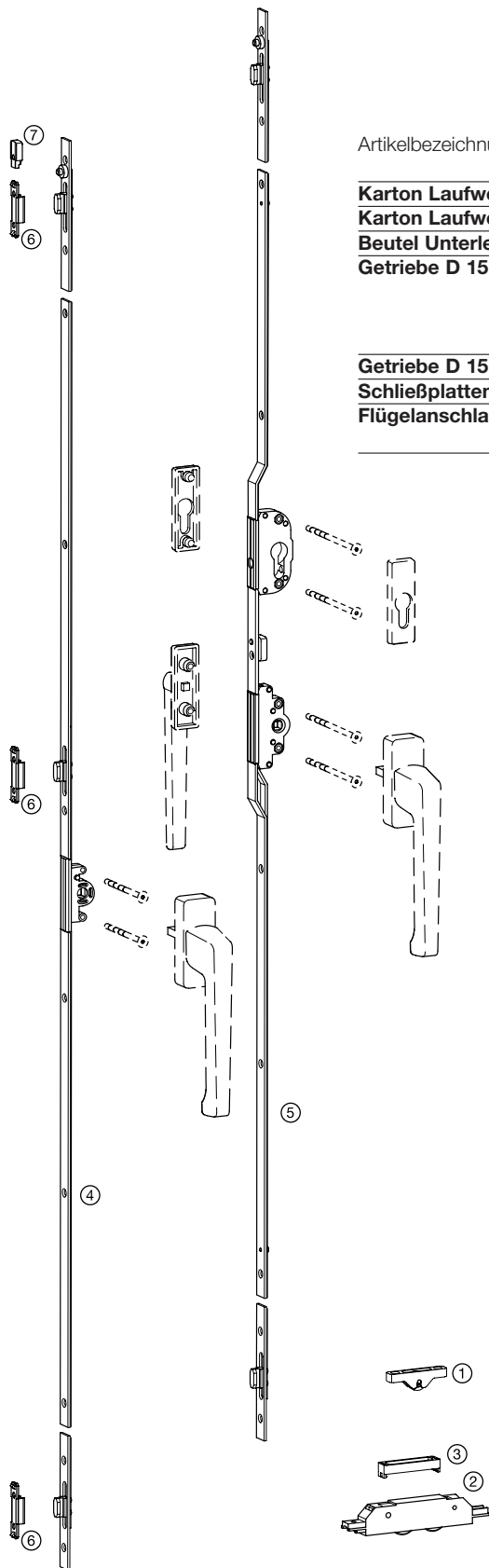

Artikelbezeichnung

Artikelbezeichnung	Artikel-Code	Bedarf pro Flügel	Schließstellen	
Karton Laufwerke S 50 ① ⑦	197123	1	-	
Karton Laufwerke S 120 ② ⑦	196202	1	-	
Beutel Unterlegteile S 120 Laufwerke ③	197411	1	-	
Getriebe D 15 ④	Gr.	FH		
	600	650 - 1049	202132	2
	1000	1050 - 1849	202135	1
	1800	1850 - 2350	202138	3
Getriebe D 15, abschließbar ⑤	1800	1850 - 2350	202213	1
Schließplatten ⑥			196196	n. FH
Flügelanschlag (optional) ⑧		weiß	187480	-
		schwarz	187477	2

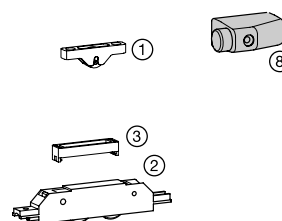
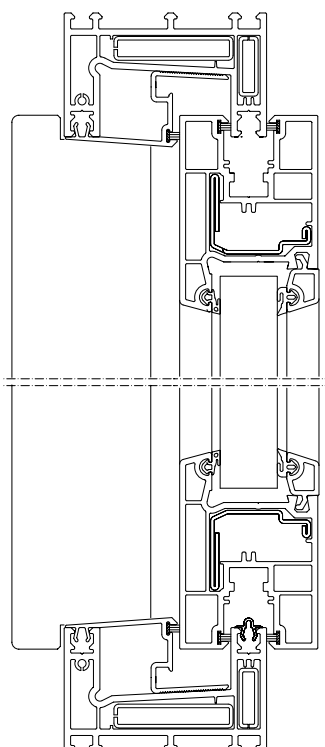



ATRIUM S 50 / S 120 - Veka Softline Schiebefenster Flügel 105.102

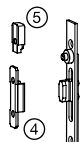

Artikelbezeichnung		Artikel-Code	Bedarf pro Flügel	Schließstellen
Karton Laufwerke S 50 ① ⑤		197123	1	-
Karton Laufwerke S 120 ② ⑤		196202	1	-
Getriebe D 7,5 ③	Gr.	FH		
	600	650 - 1049		2
	1000	1050 - 1849	1	2
	1800	1850 - 2350		3
Schließplatten ④		196196	n. FH	-
Flügelanschlag (optional) ⑥		weiß		-
		schwarz	2	-

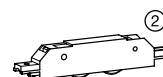
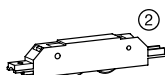
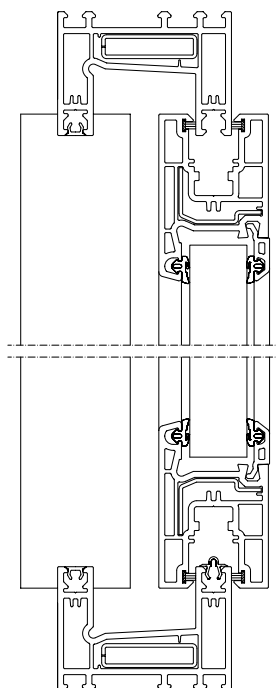
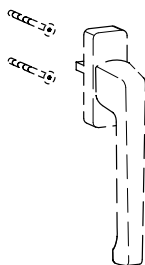

ATRIUM S 50 - Veka Softline Schiebefenster, Flügel 105.712

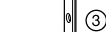
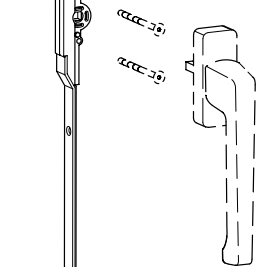
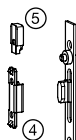

Artikelbezeichnung		Artikel-Code	Bedarf pro Flügel	Schließstellen
Karton Laufwerke S 50 ① ⑤		197123	1	-
Getriebe D 7,5 ③	Gr. FH			
	600 650 - 1049	202105		2
	1000 1050 - 1849	202108	1	2
	1800 1850 - 2350	202111		3
Schließplatten ④		196196	n. FH	-
Flügelanschlag (optional) ⑥	weiß	187480		-
	schwarz	187477	2	-

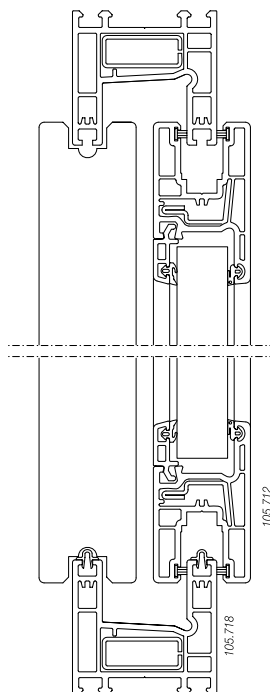



ATRIUM S 120 - Veka Topline 70, Zargenprofil 105.204

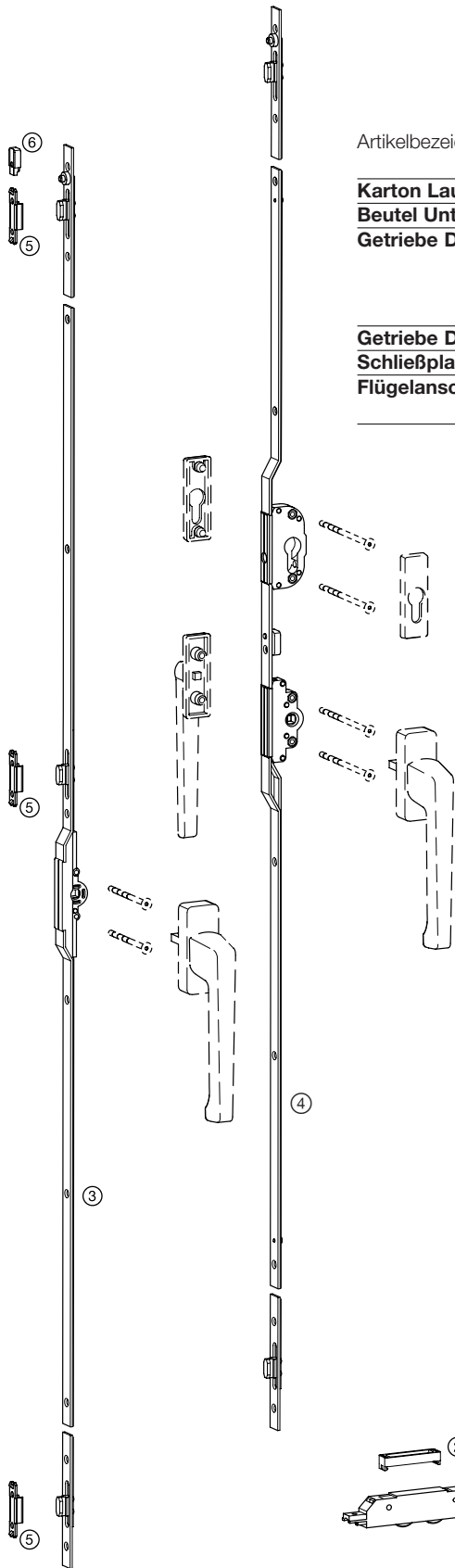

Artikelbezeichnung	Artikel-Code	Bedarf pro Flügel	Schließstellen		
Karton Laufwerke S 120 ① ⑥	196202	1	-		
Beutel Unterlegteile S 120 Laufwerke ②	197414	1	-		
Getriebe D 7,5 ③	Gr.	FH			
	600	650 - 1049	202105	2	
	1000	1050 - 1849	202108	1	2
	1800	1850 - 2350	202111		3
Getriebe D 15, abschließbar ④	1800	1850 - 2350	202213	1	2
Schließplatten ⑤			196196	n. FH	-
Flügelanschlag (optional) ⑦		weiß	187480		-
		schwarz	187477		2

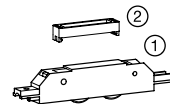
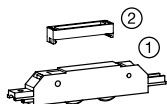
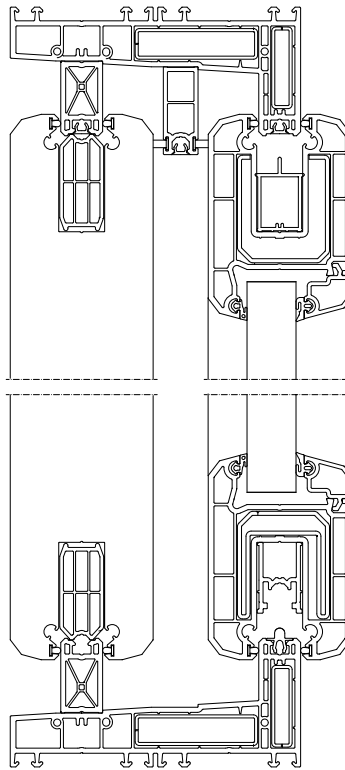



ATRIUM S 50 / S 120 - Wymar P 2400

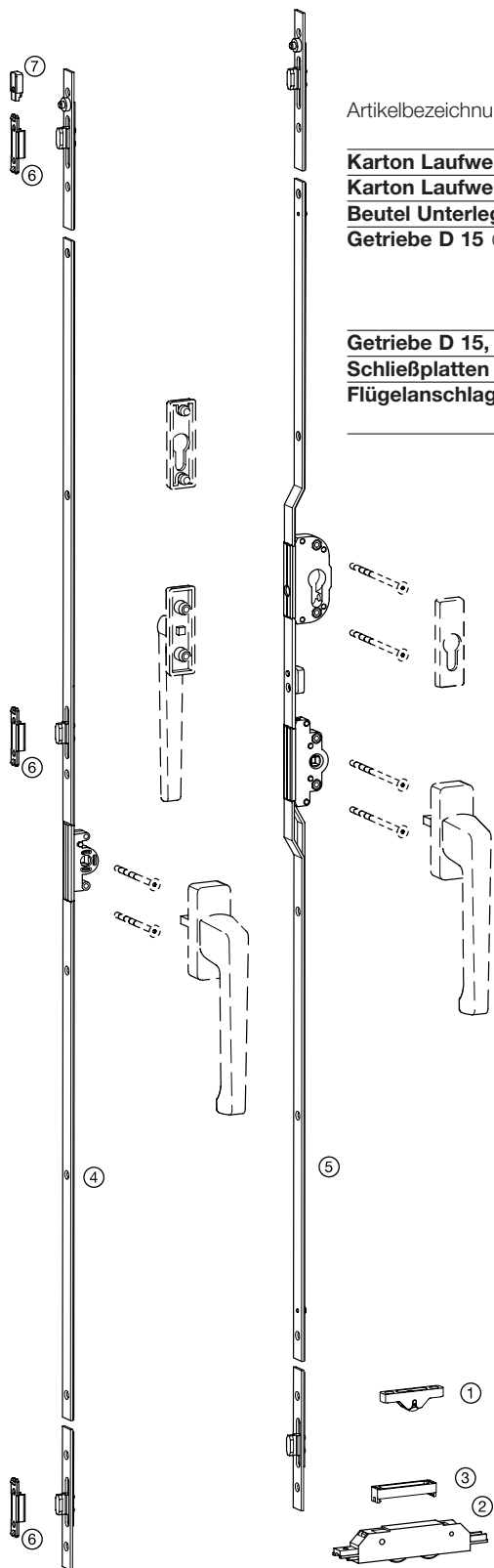

Artikelbezeichnung

Artikelbezeichnung	Artikel-Code	Bedarf pro Flügel	Schließstellen		
Karton Laufwerke S 50 ① ⑦	197123	1	-		
Karton Laufwerke S 120 ② ⑦	196202	1	-		
Beutel Unterlegteile S 120 Laufwerke ③	197012	1	-		
Getriebe D 15 ④	Gr.	FH			
	600	650 - 1049	202132	2	
	1000	1050 - 1849	202135	1	2
	1800	1850 - 2350	202138		3
Getriebe D 15, abschließbar ⑤	1800	1850 - 2350	202213	1	2
Schließplatten ⑥			195930	n. FH	-
Flügelanschlag (optional) ⑧		weiß	187480		-
		schwarz	187477	2	-

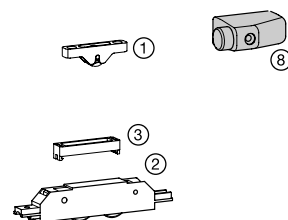
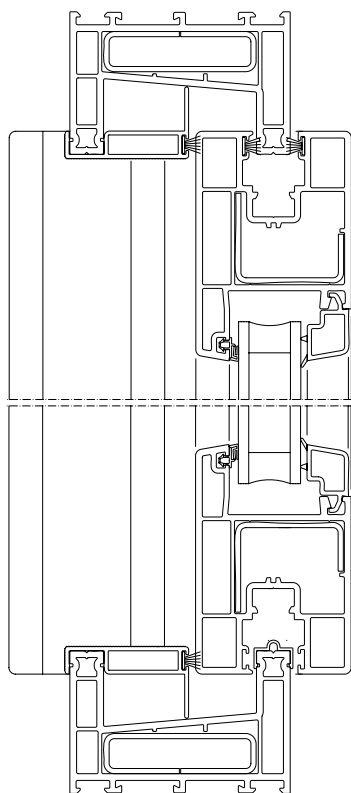



Notizen



Notizen

Sie werden's merken, wenn es HAUTAU ist.



HAUTAU GmbH
Postfach 11 51
D 31689 Helpsen
Fon +49 5724/393-0
Fax +49 5724/393-125
Info@HAUTAU.de

www.HAUTAU.de



HAUTAU